

### ◆Characteristic / 特點 :

- T-shaped housing design, saving space. / T型設計可省空間
- N.O./N.C. function switchable by different wires./ N.O./N.C.可用選擇線切換
- Easy to install. / 體積小(30x45.9x31.9mm)安裝容易
- Special design for bending resistance. / 接線使用特殊材質耐彎曲
- Superior waterproof IP67.



### ◆Specifications / 規格表 :

Model / 型號	NPN L.on/D.on	PTQ18-DU10/40N	PTQ18-DU10/40NK1
	PNP L.on/D.on	PTQ18-DU10/40P	PTQ18-DU10/40PK1
Sensing type / 檢出方式	Diffuse reflection/擴散反射式		
Sensing distance / 檢出距離	10cm / 40cm , white paper 10 x 10 (10/40cm)		
Emitting light / 發光源	Infrared LED 850nm		
Operating voltage / 工作電壓	DC12~24V		
Current Consumption / 消耗電流	20mA Max.		
Load current / 負載電流	100mA Max. at DC24V		
Response time / 反應時間	1.5 ms Max.		
Insulation resistance / 隔離阻抗	20MΩ min. (DC500V)		
Voltage withstandability / 絕緣耐壓	AC1000V 60Hz for 60 Sec.		
Operating temperature/工作溫度	- 25 °C ~ + 60 °C		
Ambient humidity / 工作溼度	35% ~ 85% RH		
Protection degree / 防水等級	IP67		
Material / 外觀材質	ABS		
Wiring method / 出線方式	Pre-wired Ø4.2 x 2 M / 3-wires 出線	M12 plug-in connector type / M12接頭	
Weight / 重量	Approx.68.5g		Approx.18g

### ◆Dimensions/尺寸圖 :

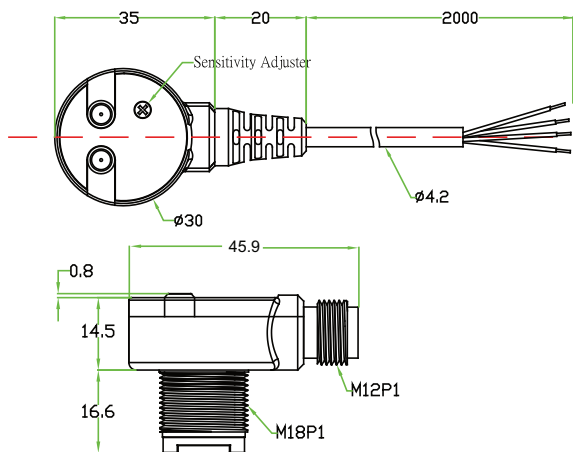

### PTQ18-DU□

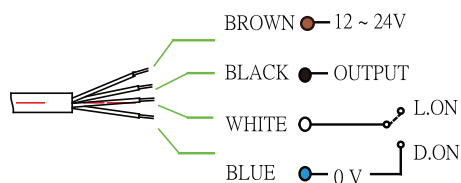

### PTQ18-DU□K1

