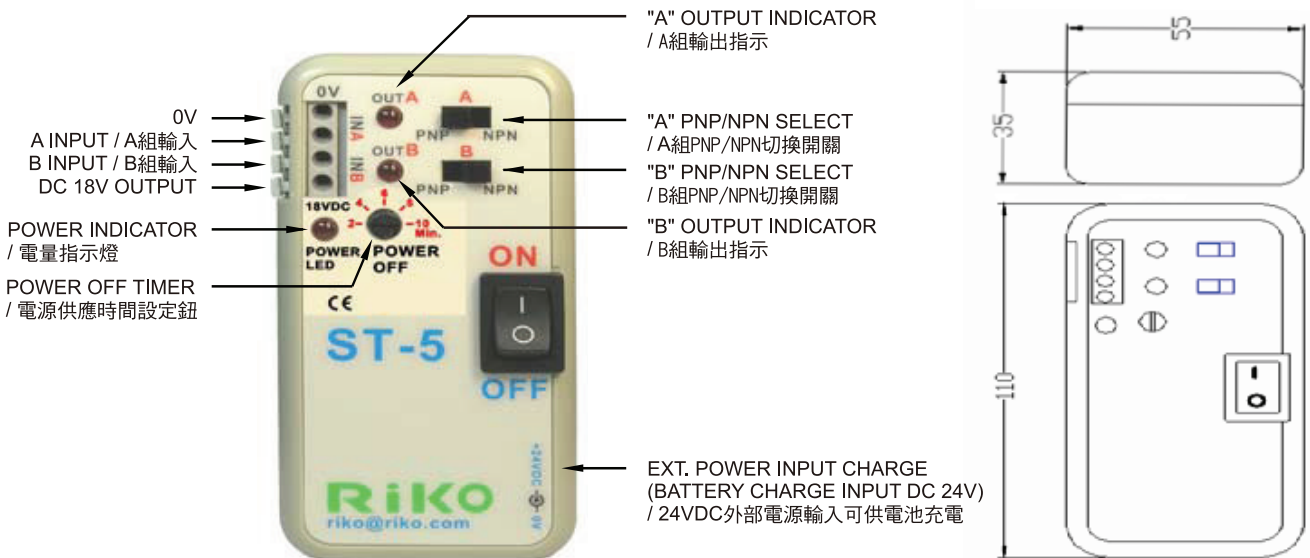

Photo Sensor  
Area Sensor  
Inductive Proximity Sensor  
Capacitive Proximity Sensor  
Timer / Counter  
Others  
Accessories

### ◆ Characteristics / 特性 :

- Used to check photoelectric and proximity sensor.  
/可檢測光電開關與近接開關並供應18VDC給SENSOR使用
- Two LED indicators and two select switches for NPN or PNP.  
/提供二組NPN及PNP輸入測試
- Use DC24V to recharge the battery .  
/可使用DC24V外部電源來進行電池充電
- Auto power off timer for saving power.  
/可設定電源供應時間來節省電力
- LED indicator blinks when low power.  
/當電量不足時,指示燈會閃爍
- Power source : DC24V or 18V Rechargeable battery .  
/使用電源為外部DC24V或內部一顆18V電池

### ◆ Panel description / 功能位置 :



### ◆ BATTERY CHARGER : ES18U24-P1J (OPTION)



Series	Model	Dimension
ES18U	ES18U24-P1J	79x54x33 mm
Power output		DC 24V 0.75A

### ◆ BATTERY : ST-5-B01

Lithium Polymer Rechargeable Battery.



60x30mm