

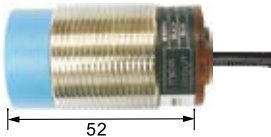
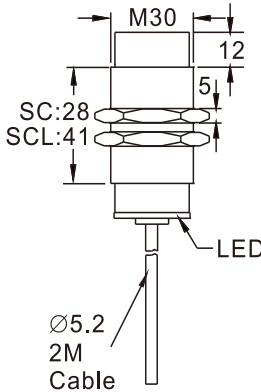
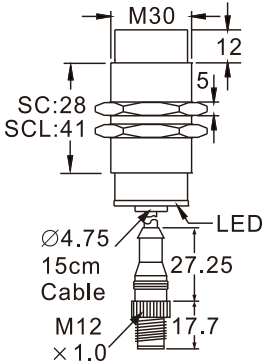
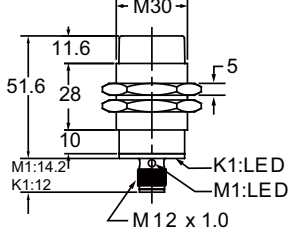
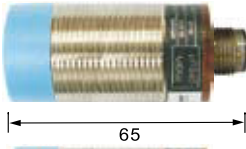
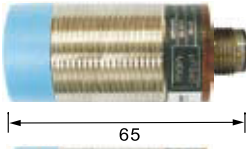
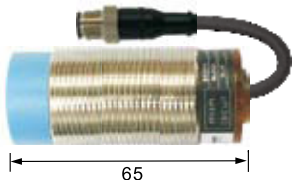

◆ Specifications / 規格表 :

Photo Sensor	SC3015-□ 																														
Area Sensor	SC3015-□K1/M1 																														
Inductive Proximity Sensor	 <p>K1 Plastic</p>  <p>M1 Nickel plated brass</p>																														
Capacitive Proximity Sensor	SCL3015-□K 																														
Timer / Counter																															
Others	<p>Output method / 輸出模式</p> <table border="1"> <tr> <td>NPN N.O.</td> <td>SC□3015-N</td> <td>SC□3015-NK</td> <td>SC3015-NK1/M1</td> </tr> <tr> <td>NPN N.C.</td> <td>SC□3015-N2</td> <td>SC□3015-N2K</td> <td>SC3015-N2K1/M1</td> </tr> <tr> <td>PNP N.O.</td> <td>SC□3015-P</td> <td>SC□3015-PK</td> <td>SC3015-PK1/M1</td> </tr> <tr> <td>PNP N.C.</td> <td>SC□3015-P2</td> <td>SC□3015-P2K</td> <td>SC3015-P2K1/M1</td> </tr> <tr> <td>NPN N.O./N.C. PNP N.O./N.C.</td> <td>SC3015-KP2</td> <td>SC3015-KP2K</td> <td>-</td> </tr> <tr> <td>SCR N.O.</td> <td>SC3015-A</td> <td>SC3015-AK</td> <td>-</td> </tr> <tr> <td>SCR N.C.</td> <td>SC3015-A2</td> <td>SC3015-A2K</td> <td>-</td> </tr> </table>	NPN N.O.	SC□3015-N	SC□3015-NK	SC3015-NK1/M1	NPN N.C.	SC□3015-N2	SC□3015-N2K	SC3015-N2K1/M1	PNP N.O.	SC□3015-P	SC□3015-PK	SC3015-PK1/M1	PNP N.C.	SC□3015-P2	SC□3015-P2K	SC3015-P2K1/M1	NPN N.O./N.C. PNP N.O./N.C.	SC3015-KP2	SC3015-KP2K	-	SCR N.O.	SC3015-A	SC3015-AK	-	SCR N.C.	SC3015-A2	SC3015-A2K	-		
NPN N.O.	SC□3015-N	SC□3015-NK	SC3015-NK1/M1																												
NPN N.C.	SC□3015-N2	SC□3015-N2K	SC3015-N2K1/M1																												
PNP N.O.	SC□3015-P	SC□3015-PK	SC3015-PK1/M1																												
PNP N.C.	SC□3015-P2	SC□3015-P2K	SC3015-P2K1/M1																												
NPN N.O./N.C. PNP N.O./N.C.	SC3015-KP2	SC3015-KP2K	-																												
SCR N.O.	SC3015-A	SC3015-AK	-																												
SCR N.C.	SC3015-A2	SC3015-A2K	-																												
Accessories																															
Sensing type / 檢出方式		Unshielded / 非隔離型																													
Description / 外型		Standard / 標準M30																													
Standard sensing object / 標準檢測物		Iron 30 x 30 x 1 mm																													
Sensing distance / 檢出距離		15 mm																													
Secure sensing distance / 建議距離		0 ~ 12 mm																													
Hysteresis / 遲滯		≤ 10 % of sensing distance																													
Response time / 反應時間		DC Type 3.3 ms Max. or AC Type 100ms																													
Operating voltage / 工作電壓		DC 12 ~ 24V or AC 90 ~ 260V																													
Current consumption / 消耗電流		DC : ≤ 8 mA no-load or AC : 2 mA Max.																													
Load current / 負載電流		DC : 100 mA Max at DC 24V or AC : 5 ~ 300 mA Max																													
Leakage current / 漏電流		≤ 1.1 mA no-load																													
Residual voltage / 殘餘電壓		≤ DC 1.5V																													
Insulation resistance / 隔離阻抗		20M Ω min. (DC500V)																													
Voltage withstandability / 絕緣耐壓		AC1000V 60Hz for 60 Sec.																													
Operating temperature / 工作溫度		-20°C ~ +60°C																													
Protection degree / 防水等級		IP 66																													
Wiring method / 出線方式		N/P : Ø5.2x 2M / 3-wires (KP2 : Ø5.2x2M / 4-wires) AC : Ø5.2x 2M / 2-wires	M12 pigtailed type / M12 接頭15cm 電線式	M12 plug-in connector type / M12 接頭																											
Weight / 重量		SC SCL	Approx. 135g Approx. 170g	Approx. 80g Approx. 115g K1:Approx.70g/M1:Approx. 90g K1:Approx.105g/M1:Approx. 125g																											